

Communication Interface Module Replacement

Service Operations

Caution: Refer to [Service Programming System \(SPS\) Notice](#) in the Preface section.

If the telematics module is not enabled:

A low battery voltage alert (when the battery voltage is low) is transmitted to the Telematics Call Centre.

Removal Procedure

Caution: Refer to [Battery Disconnect Caution](#) in the Preface section.

1. Using a scan tool, select service mode to disable the telematics module. Refer to [Service Programming System \(SPS\)](#).
2. Disconnect the battery ground cable. Refer to [Battery Negative Cable Disconnection and Connection](#).
3. Remove the I/P compartment. Refer to [Instrument Panel Compartment Replacement](#).

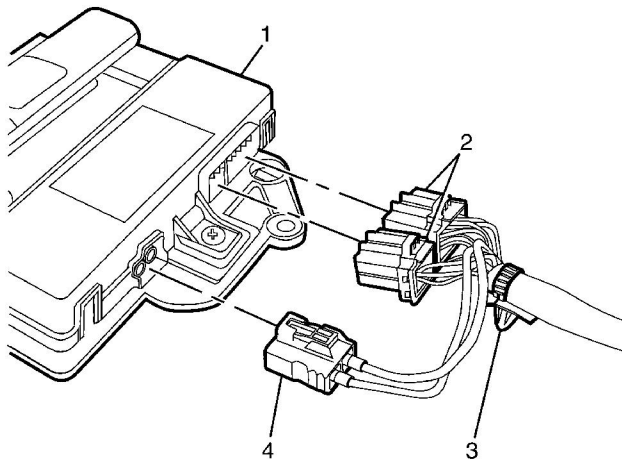

4. Detach the electrical wiring harness cable tie (3) from the telematics module (1).
5. Disconnect the GPS antenna connector (4) and the telematics module connectors (2) from the telematics module (1).

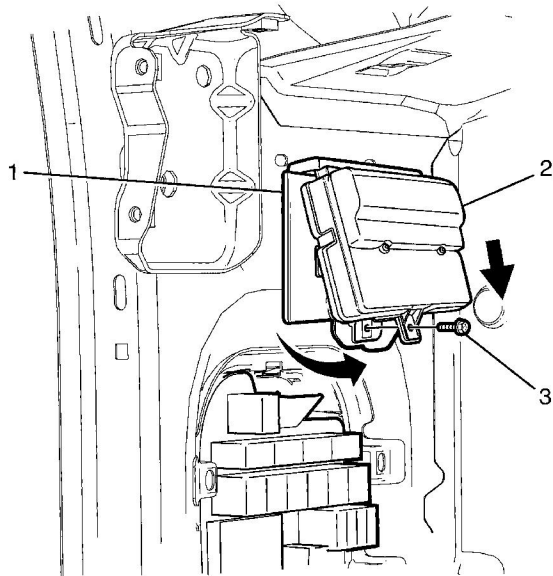

6. Remove the telematics module to retaining bracket retaining screw (3).
7. Remove the telematics module (2), by manoeuvring it forward and sliding it out of the retaining bracket (1).

Installation procedure

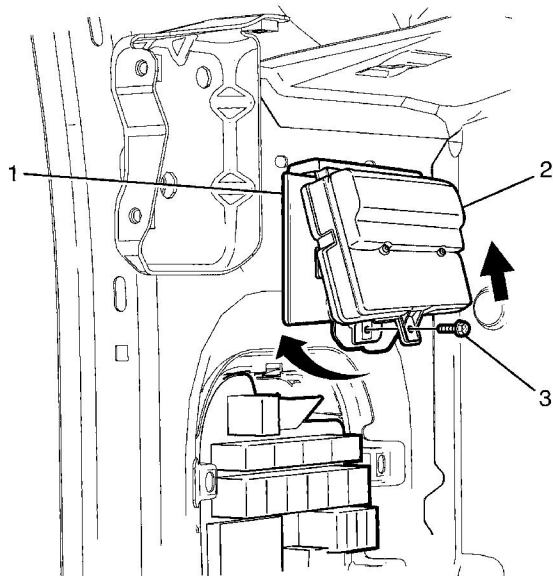

1. Install the top of the telematics module (2) into the retaining bracket (1) and locate the bottom end of the telematics module (2) into the bottom end of the retaining bracket (1).

Notice: Refer to [Fastener Notice](#) in the Preface section.

2. Install the telematics module to retaining bracket retaining screw (3).

Tighten

Tighten the screw to 2.0 N·m (18 lb in).

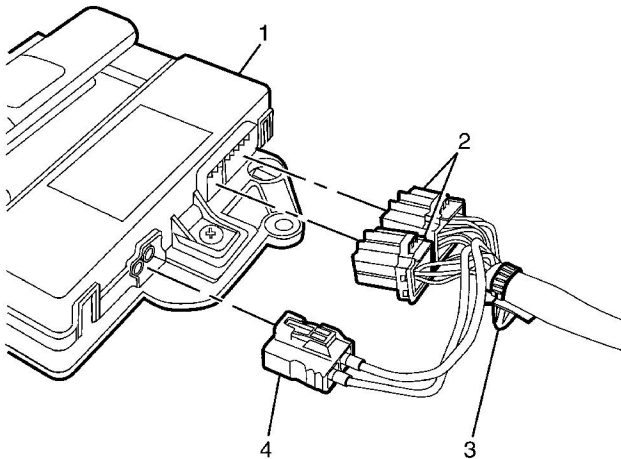

3. Connect the GPS antenna connector (4) and the telematics module connectors (2) to the telematics module (1).
4. Attach the electrical wiring harness cable tie (3) to the telematics module (1).
5. Install the I/P compartment. Refer to [Instrument Panel Compartment Replacement](#).
6. Install the I/P compartment. Refer to [Instrument Panel Compartment Replacement](#).
7. Connect the battery ground cable to the battery. Refer to [Battery Negative Cable Disconnection and Connection](#).

Important: If replacing a telematics module, the new module will require the programming of the correct system software level.

8. Reprogram the telematics module and select the system software required (GM Fleetview, Secure or Assist Ultra). Refer to [Service Programming System \(SPS\)](#).

Important: If replacing a telematics module, the new module will require registration.

9. Register the telematics module. Refer to [Communication Interface Module Registration](#).

Important: If the telematics module service mode remains enabled, the telematics system does not have full functionality.

10. Using a scan tool, select active mode to enable the telematics module. Refer to [Service Programming System \(SPS\)](#).